



## LioN-M I/O modules

### Technical Manual

0970 PSL 700 | 0970 PSL 701



## LioN-M I/O modules for Profibus

### 0970 PSL 700

16 digital channels (p-switching), channels can be used universally as inputs or outputs, with rotary address switches

### 0970 PSL 701

16 digital inputs (p-switching), with rotary address switches

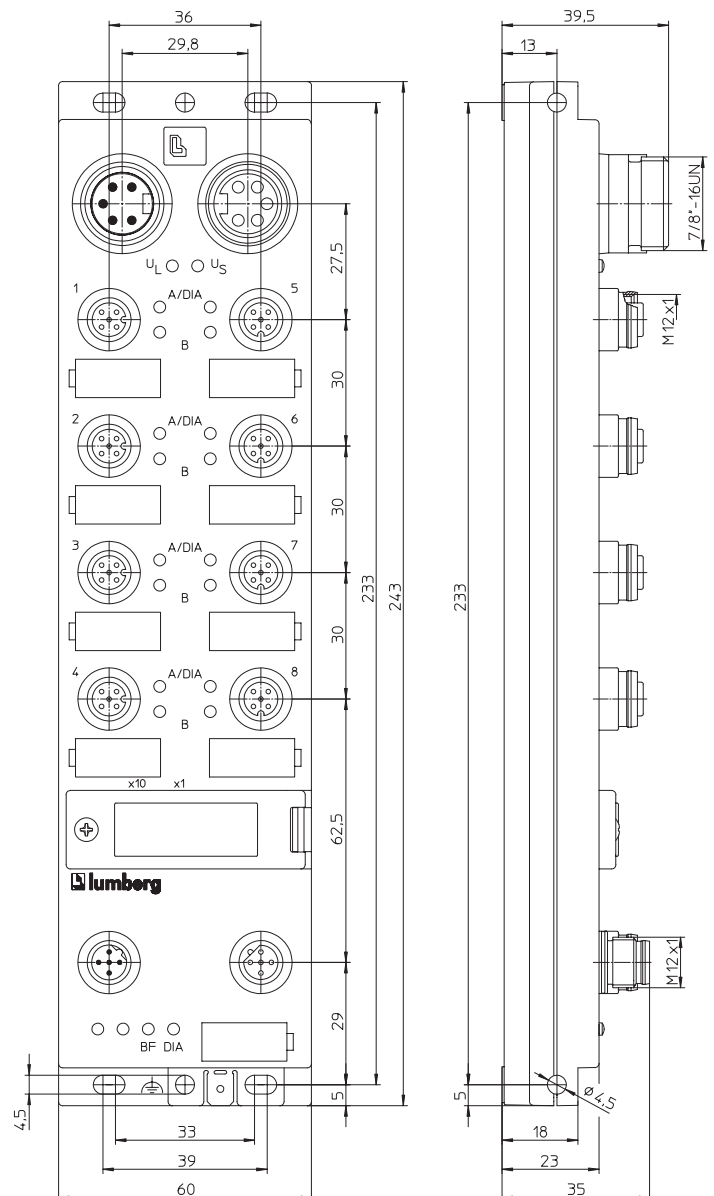

## 1. About this Manual

Please read the assembly and operating instructions in this Manual carefully before putting the LioN-M type module into operation. The Manual should be stored in a place that is accessible for all users.

The texts, illustrations, diagrams and examples used in this Manual are solely for the purpose of explaining the operation and use of input/output modules of the series type LioN-M.

Please contact us if you have any further questions concerning installation and commissioning of the devices. We will be happy to be of assistance to you at any time.

Lumberg Automation – Belden Deutschland GmbH  
Im Gewerbepark 2  
58579 Schalksmühle  
Tel. +49 (0) 23 55 / 83-01  
Fax +49 (0) 23 55 / 83-333  
support@lumberg-automation.com  
www.lumberg-automation.com

Lumberg Automation reserves the right to alter these technical modifications or to modify this Manual at any time without notice.

### 1.1 Explanations of symbols used

#### 1.1.1 Use of notes

Notes concerning important information are specially marked. They are displayed as follows:

#### 1.1.2 Use of hazard notes

Notes concerning hazards are marked as follows:

 **DANGER:**  
Non-compliance with respective precautionary measures will expose the user to life-threatening dangers and health hazards.

 **NOTE:**  
Non-compliance with precautionary measures can result in possible damage to equipment and other property.

### 1.2 Safety Guidelines

#### 1.2.1 Certified usage

The devices described in this Manual are used as decentralised input/output assemblies in a Profibus DP network.

Our products have been developed, produced, tested and documented in compliance with safety standards. No hazards to personnel or property are to be anticipated under normal conditions in connection with these products when the handling regulations and safety instructions described here for project planning, assembly and specified operations are complied with.

The modules fulfill the requirements of the

- EMC guideline (89/336/EWG, 93/68/EWG and 93/44/EWG)
- Low-voltage Guideline (73/23/EWG)
- are designed for utilization in the industrial area. The industrial environment is characterised by the fact that users are not directly connected with the public low-voltage mains. Additional measures are to be implemented for utilization in residential quarters and in business and trade areas.

**Warning!**  
This installation can cause radio interference in resident areas; the user may be asked to implement appropriate measures.

The error-free, secure operation of the product requires proper transport, storage, set-up and assembly, as well as careful operation. The intended operation of the device can only be guaranteed when the housing is mounted in its entirety. All of the other devices connected with this device must fulfill the requirements contained in EN 61558-2-4 and EN 61558-2-6.

Project planning, installation, commissioning, maintenance and testing of the devices may not be performed by anyone other than an electrician who has successfully completed recognised training courses and who is familiar with the safety standards of automation technology.

### 1.3 Qualified personnel

The personnel requirements are oriented towards the requirements profile outlined by ZVEI and VDMA. Only skilled electricians who are familiar with the contents of this Manual are permitted to install or service the products described.

These are individuals who

- assess the tasks to be performed on the basis of their professional training, knowledge and experience and on the basis of their knowledge of the pertinent standards, and who can recognise possible dangers.
- have the same knowledge levels as those who have completed a specialised training course, thanks to many years of professional involvement in a comparable area.

## 2. Directions for field installation

The module is to be mounted on a level surface with at least 2 screws.

Type of mounting	Screw	Tightening torque
flat	M4 x 25/30	1.0 Nm
lateral	M4 x 70/80	1.0 Nm

A washer in accordance with DIN 125 is to be provided with all types of mounting fixtures.

The user has to comply with the safety and accident prevention regulations that apply to the specific activity being performed during project planning, installation, commissioning, maintenance and testing of the devices.

No cables or accessories may be installed except for those which fulfill the requirements and regulations governing safety, electromagnetic compatibility and, where appropriate, terminal device equipment for telecommunications and which correspond to the statement of specifications. Information concerning those cables and accessories which are authorized for installation can either be obtained from Lumberg Automation or are already described in this Manual.

No modifications may be carried out on our product hardware or software, insofar as they are not described in the Manual, except by Lumberg Automation personnel.

#### Warning!

Unqualified modifications of hardware or software or non-compliance with the warning notices listed in this Manual could lead to severe injury to persons or damage to property.

#### Important note:

The module is equipped with a grounding sheet for the purpose of discharging parasitic currents and/or for EMC stability.

It is necessary that this grounding sheet is linked with the reference earth by means of a low-impedance connection. If the mounting surface is already grounded, the connection can be made directly via the fastening screw (not with lateral mounting).

If the mounting surface is not already grounded, or if the lateral mounting holes are used, a grounding strip or a suitable PE wire is to be used!

### 3. Pin assignment

#### 3.1 Profibus DP M12 male/female connector, 5 poles, B-coded

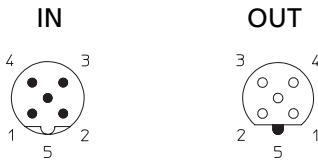

Connection	Pin	Function
Profibus DP In/Out	1	+5 V*
	2	Line A
	3	GND*
	4	Line B
	5	earth

The signals marked with \* are internal signals which the module provides for supplying a terminator. These are not permitted to be configured or redirected to other devices. Article 0979 PTX 101 is to be used as an authorized terminator.

**⚠ CAUTION, danger of destruction!**

Never place the voltage supply (24 V DC) on the data circuits (Pin 2, Pin 4) or on the internal signals (Pin 1, Pin 3).

#### 3.2 Sensor/Actuator connection, M12 female connector, 5 poles

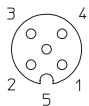

Connection	Pin	Function	
		PSL 700	PSL 701
I/O channels	1	+24 V	+24 V
	2	In/Out B	In B
	3	0 V	0 V
	4	In/Out A	In A
	5	earth	earth

#### 3.3 System/Sensor/Actuator supply, 7/8" male/female connector, 5 poles

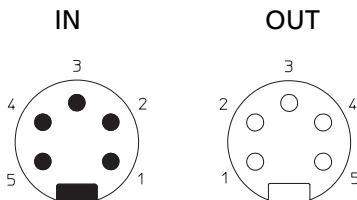

Connection	Pin	Function	
		PSL 700	PSL 701
Actuators	1	GND (0 V)	n.c.
System/Sensors	2	GND (0 V)	GND (0 V)
	3	earth	earth
System/Sensors	4	+24 V	+24 V
Actuators	5	+24 V	n.c.

All 5 poles of the integrated T connector are connected in the 0970 PSL 701 module.

## 4. Communication with the module

### 4.1 Addressing

#### a) Rotary address switches

Two rotary switches, located above the M12 bus connections behind a clear cover, are used for direct adjustment of the Profibus address. The switches for setting the tens and the ones of the address are indicated. After selecting the address via the rotary switches the address will be set internally after power is applied to the module. Therefore the power supply must be interrupted briefly if the address is changed during power-on in order to allow the module to adopt the new address.



The adjustable address range lies between 1 and 99.  
The factory setting for the address is 99.

#### b) Profibus network

It is also possible to adjust the settings of the module address via the Profibus network. Precise directions regarding procedural method can be found in the manual for your respective Profibus Master.

The rotary switches must be set to the value "00" to allow software addressing. The addressing range in such cases lies between 1 and 126.

### 4.2 Data transmission rate

The data transmission rate used is established at the start of communication between the module with the master, and is automatically detected (AutoBaud Detection).

### 4.3 Examples for integration into the control system configuration

The configuration file (gsd file) of the modules must be integrated into the control system software. The precise procedural method can be obtained from the manual for the respective control system. The following examples show the procedure for the S7 software of the Siemens Company and the CoDeSys software of the 3S Software Solutions Company.

The determination of the Profibus address and the range of the input and output bytes is automatically set by the respective configuration software, but can also be altered by the user.

**a) Configuration example in the Siemens Company's S7 Software**

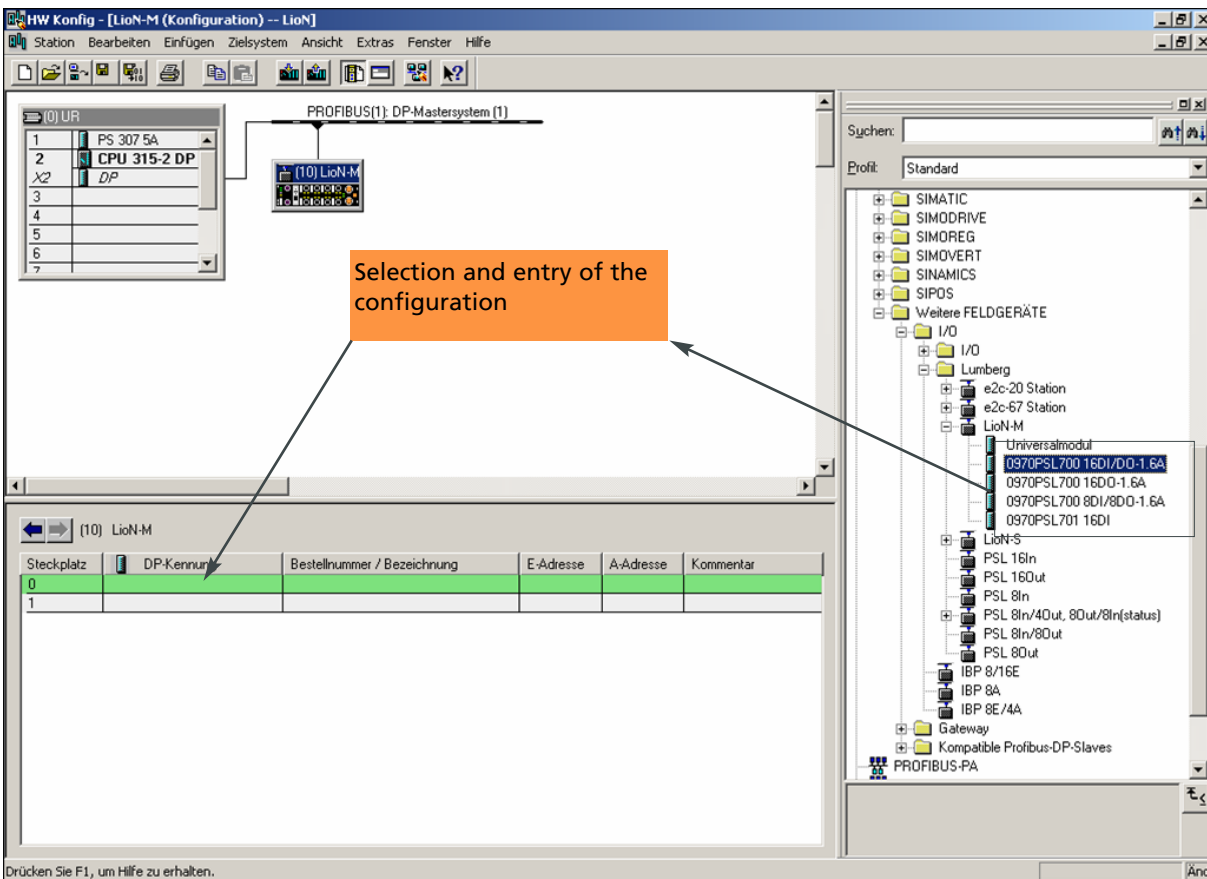
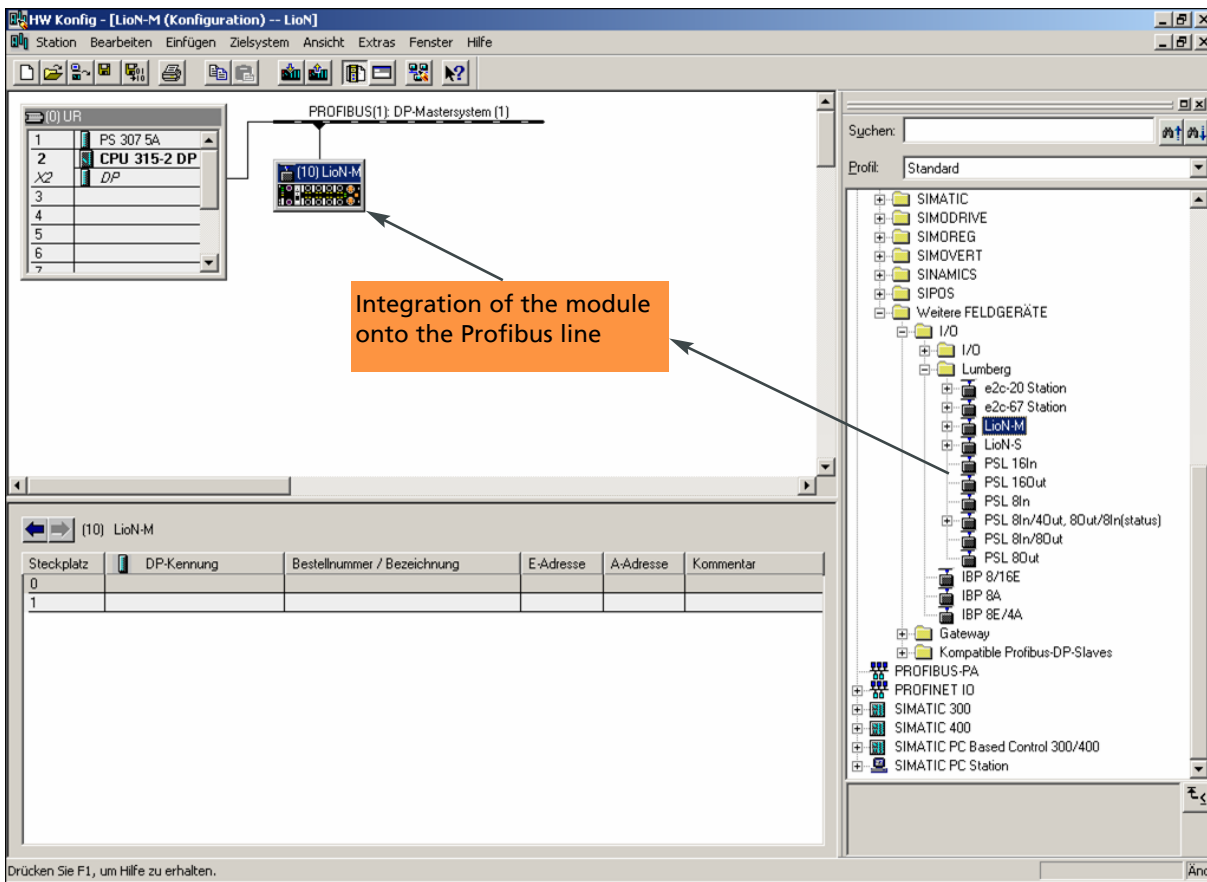

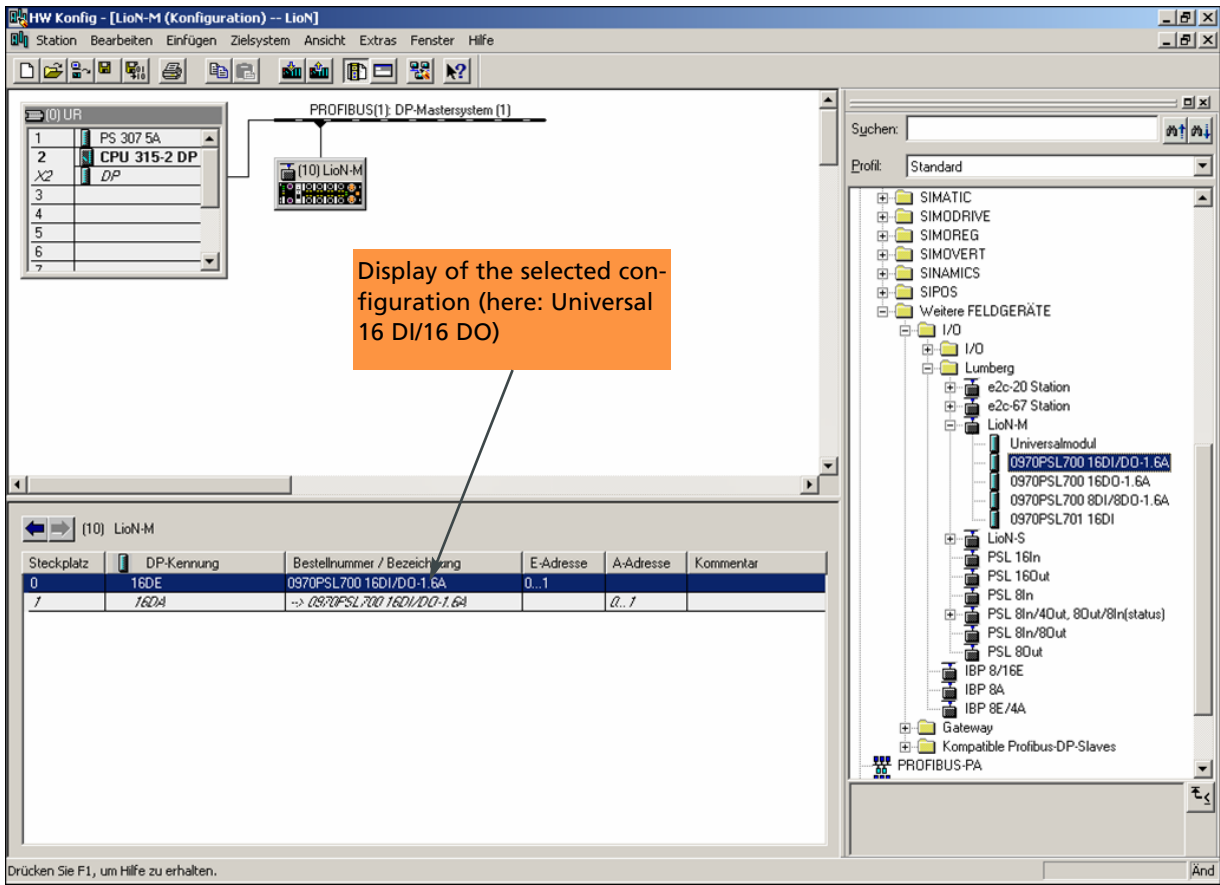

Display of the selected configuration (here: Universal 16 DI/16 DO)

Steckplatz	DP-Kennung	Bestellnummer / Bezeichnung	E-Adresse	A-Adresse	Kommentar
0	16DE	0970PSL700 16DI/DO-1.6A	0...1		
1	16DA	-> 0970PSL700 16DI/DO-1.6A		0..1	



### b) Configuration example CoDeSys of the 3S Software Solutions Co. (Moeller)

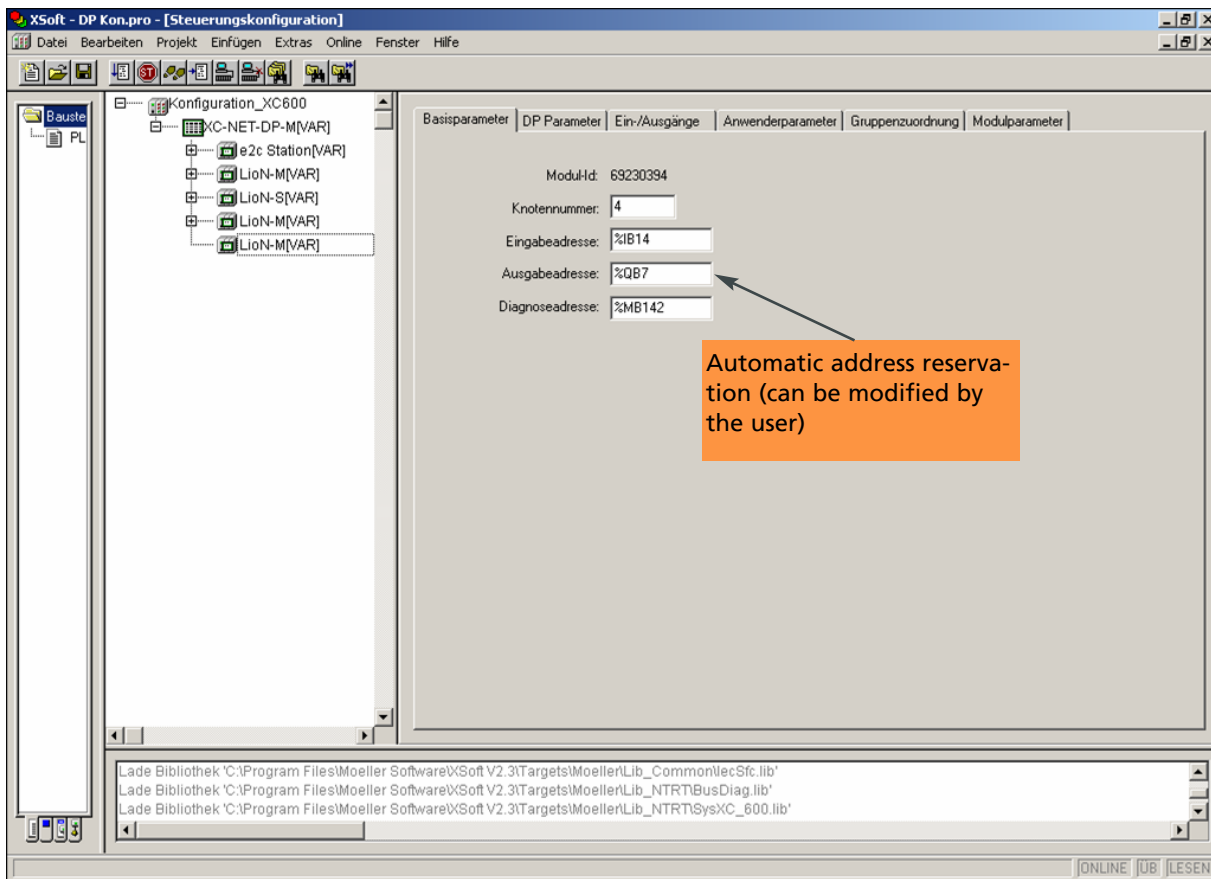
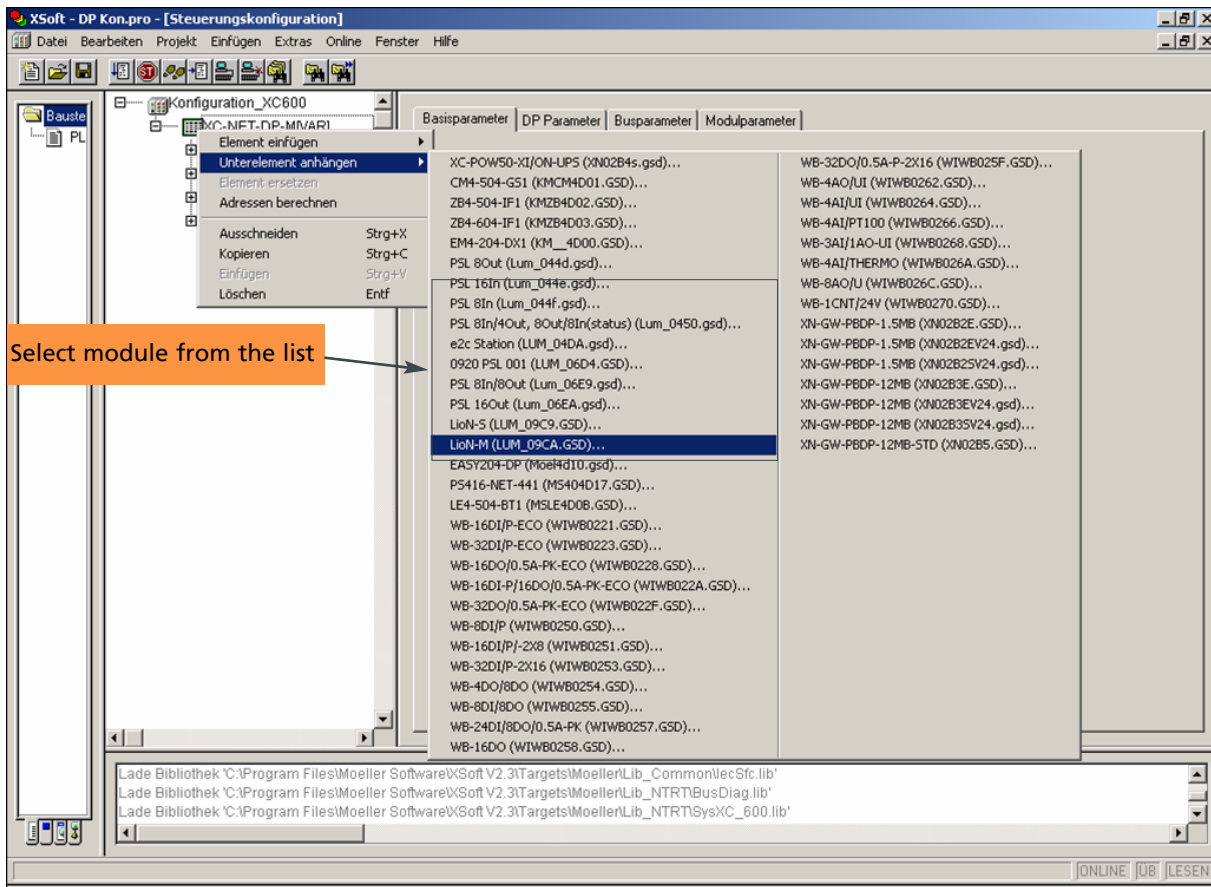

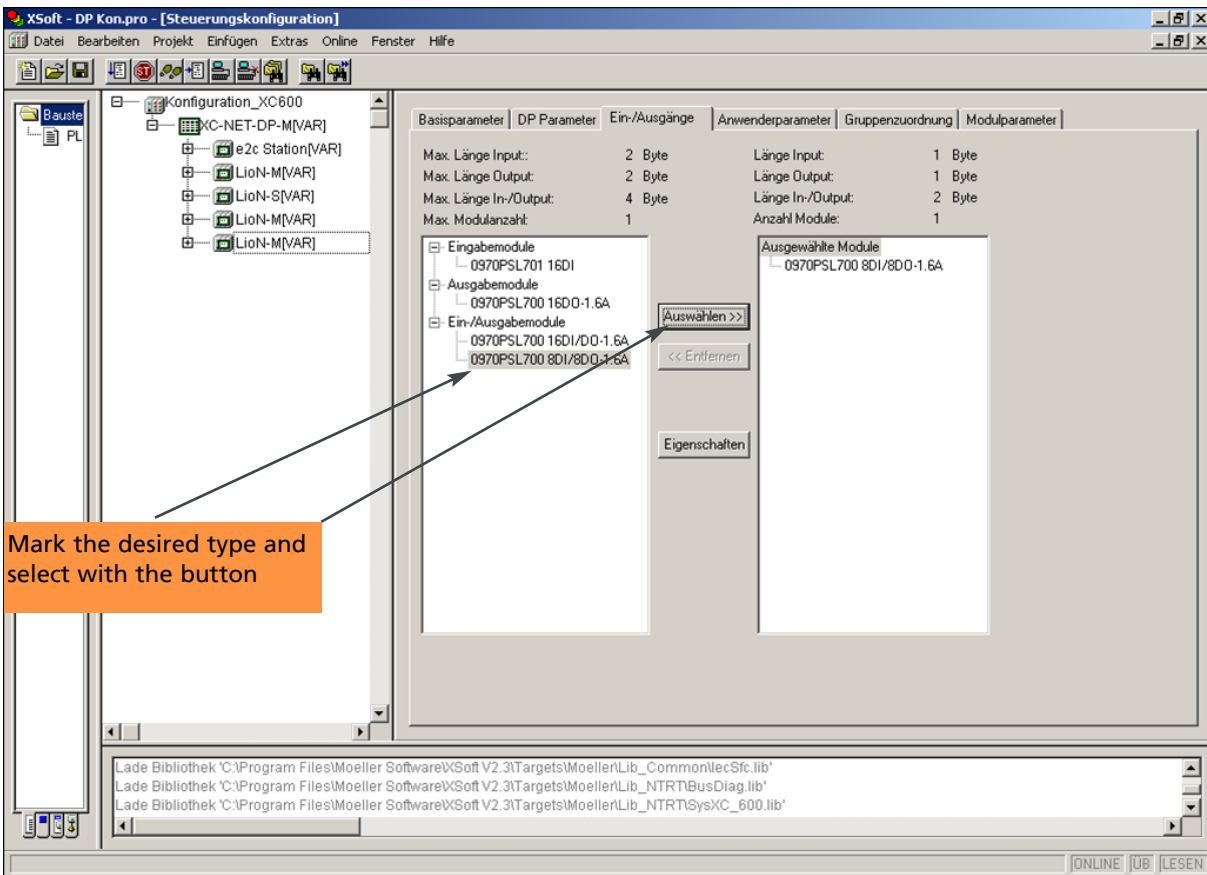
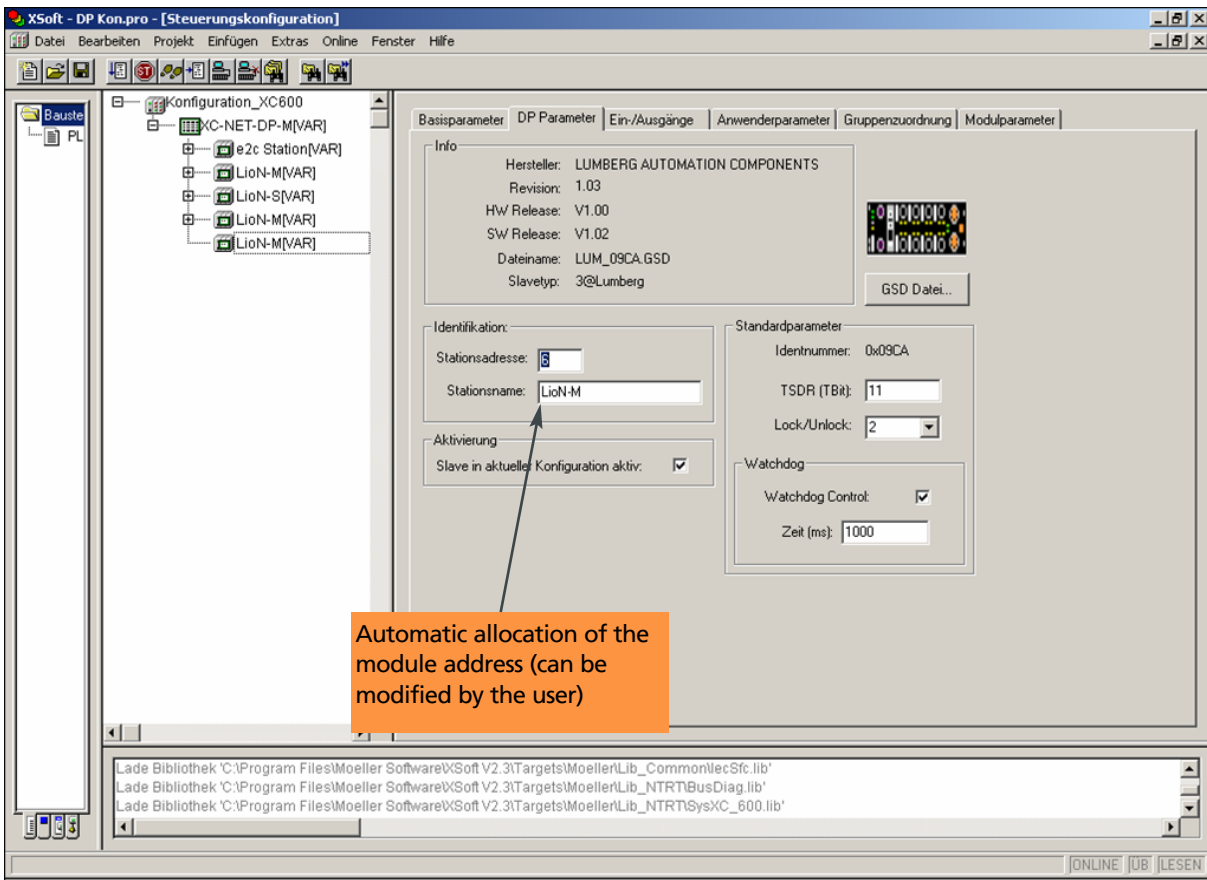

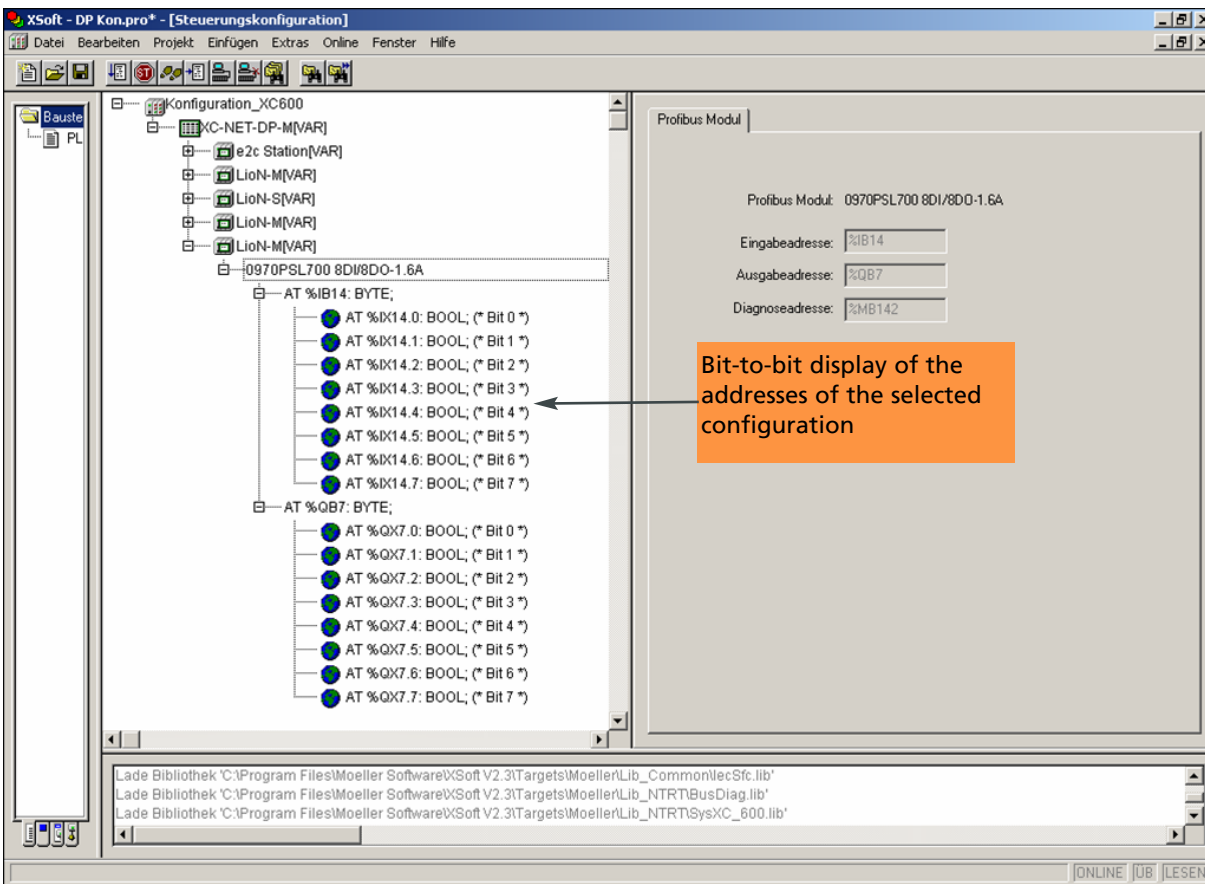
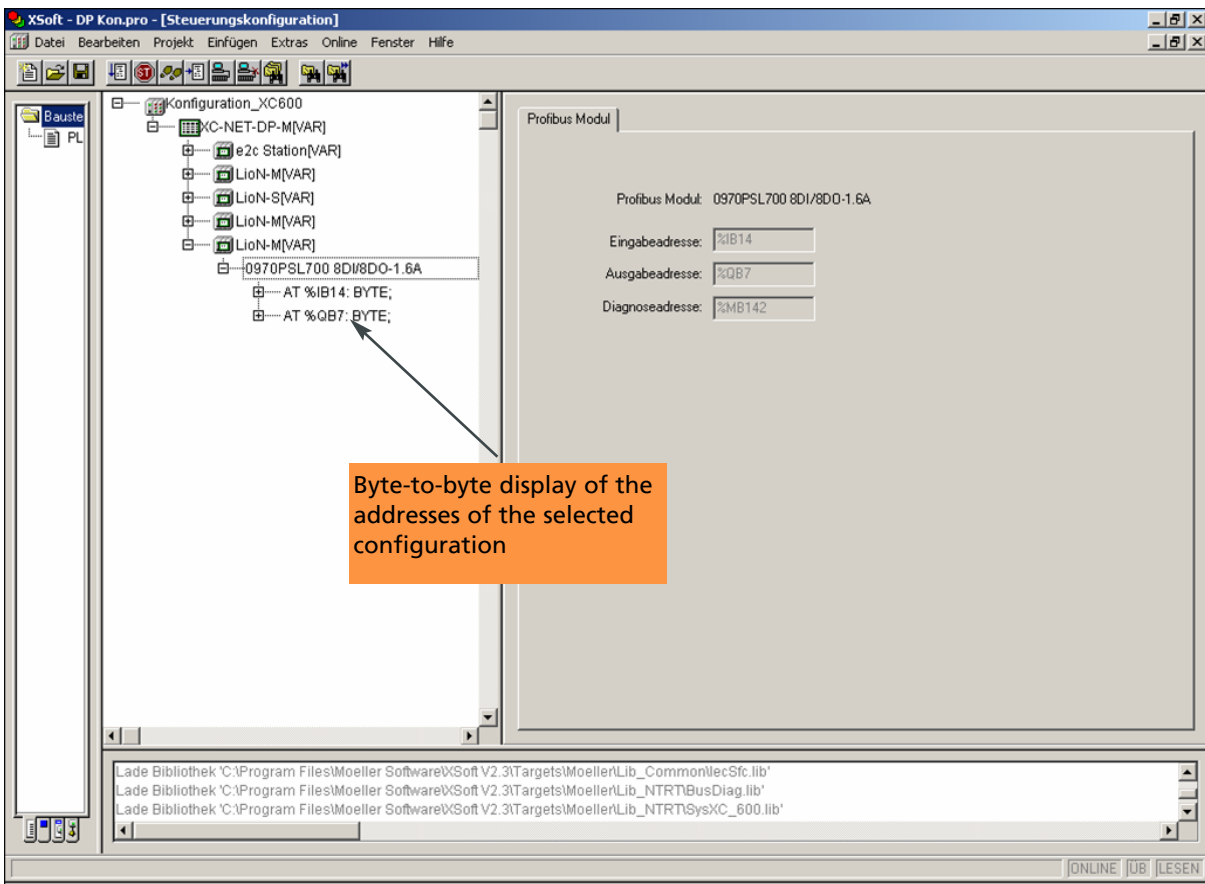

#### 4.4 Bit assignment

The Profibus telegram permits transmission of a maximum of 244 bytes of information data. Depending on utilization of the 0970 PSL 700 module, the information data with these modules consists of two or four bytes; for module 0970 PSL 701 it consists of two bytes (input only).

Bitbelegung Bit assignment								
Bit	7	6	5	4	3	2	1	0
<b>M12 Input</b>								
<b>Byte 0</b>	4B	4A	3B	3A	2B	2A	1B	1A
<b>Byte 1</b>	8B	8A	7B	7A	6B	6A	5B	5A
<b>M12 Output</b>								
<b>Byte 0</b>	4B	4A	3B	3A	2B	2A	1B	1A
<b>Byte 1</b>	8B	8A	7B	7A	6B	6A	5B	5A

When the universal module 0970 PSL 700 is used with the configuration 8 DI/8 DO, channels 1 to 4 (left-hand socket row) are allocated permanently to the input byte and channels 5 to 8 (right-hand socket row) to the output byte!

#### 4.5 Diagnostic messages

In order to make the detection of a fault easier, software diagnostics have been integrated for evaluation by the Master and LED's for visual diagnostics. The functionality and the various statuses are explained in greater detail in the following Table.

##### a) Visual by LED

Diagnoseanzeige Diagnostic indication		
LED	Anzeige Indication	Bedingung Condition
1...8 A/B	gelb yellow	Kanalstatus channel status
1...8 A/ DIA	rot red	Peripheriefehler ((Aktorunterspannung / Aktorkurzschluss / Sensorkurzschluss) periphery fault (actuator low voltage / actuator short-circuit / sensor short-circuit)
1...8 B/ DIA	rot red	Peripheriefehler ((Aktorunterspannung / Aktorkurzschluss) periphery fault (actuator low voltage / actuator short-circuit)
U <sub>S</sub>	grün green	Sensor-/Systemversorgung sensor/system power supply
U <sub>L</sub>	grün green	Aktorversorgung actuator power supply
BF	rot red	Busfehler Bus error
DIA	rot red	Sammelanzeige für Peripheriefehler Common indication for periphery faults

## b) Profibus network

In case of an error Profibus devices send a diagnostic message to the Master (sensor/actuator short circuit, undervoltages). The Master then requests the diagnostics telegram of the device, which can consist of a maximum of 244 bytes, the same as the information data. The first six bytes (byte 0 to byte 5) of this diagnostics telegram are standardized and the

content cannot be altered. The user-specific diagnostics begins with byte 6.

The user-specific diagnostics is made up of 7 bytes with the present device. The overall construction of the diagnostics telegram can be obtained from the following Table.

### Diagnostic structure of the Profibus DP

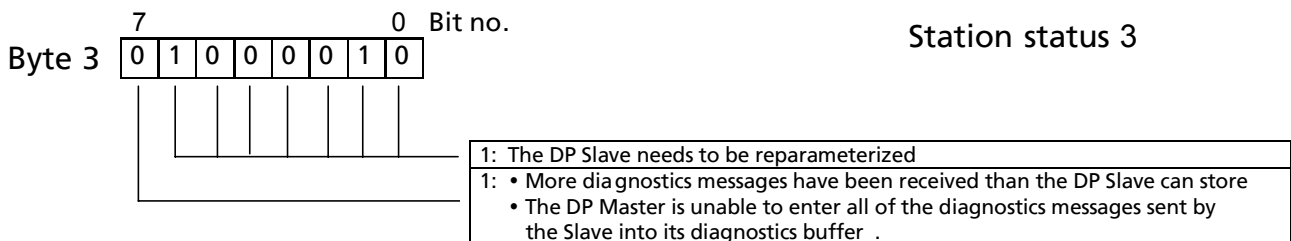
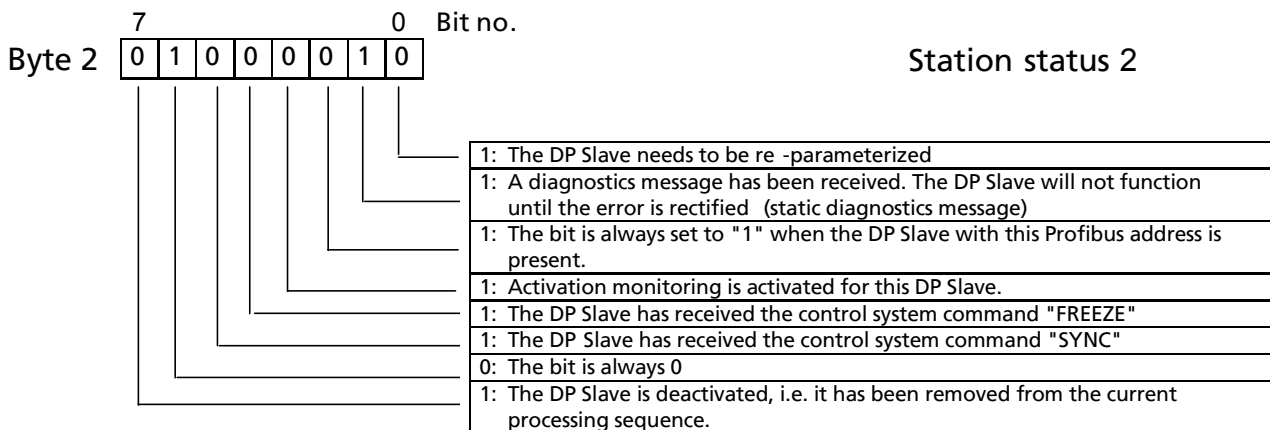
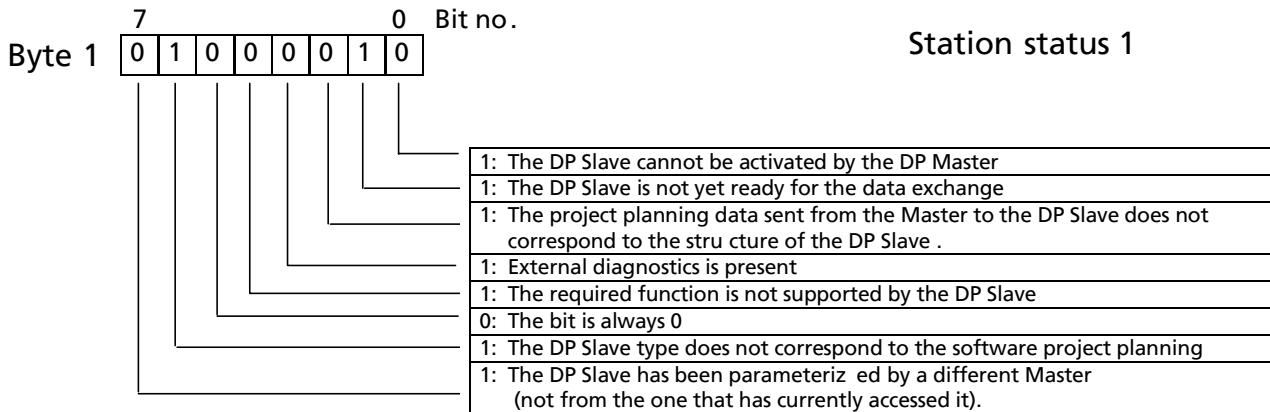

Byte 4 High-Byte  
Byte 5 Low-Byte

} Manufacturer identification

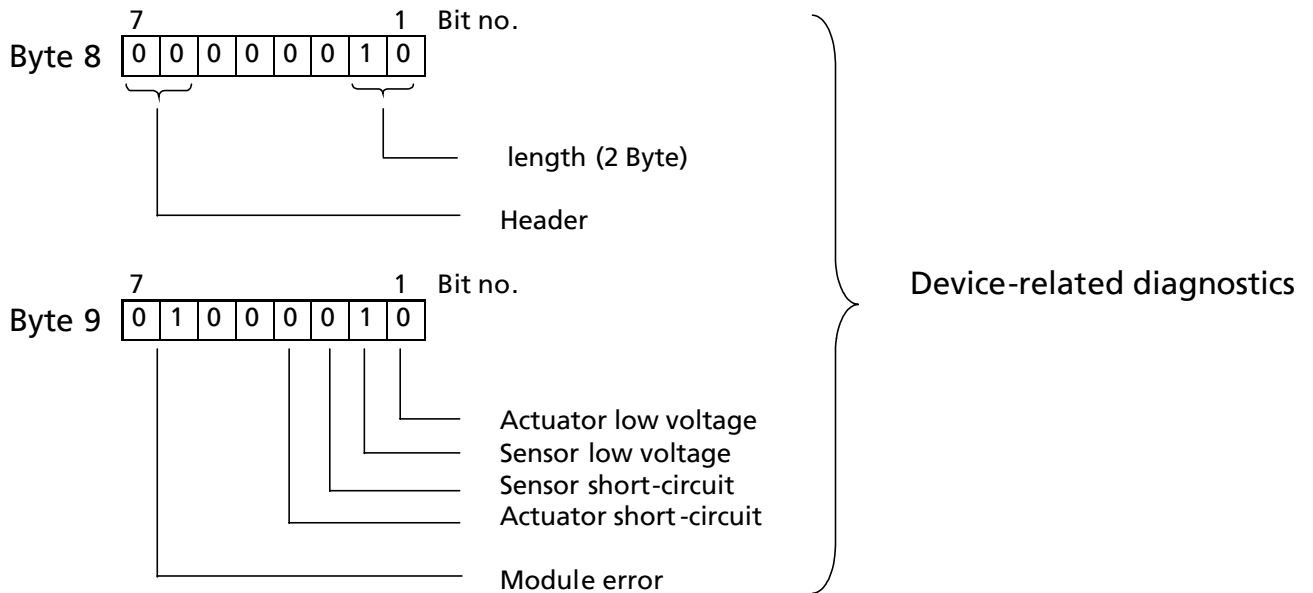
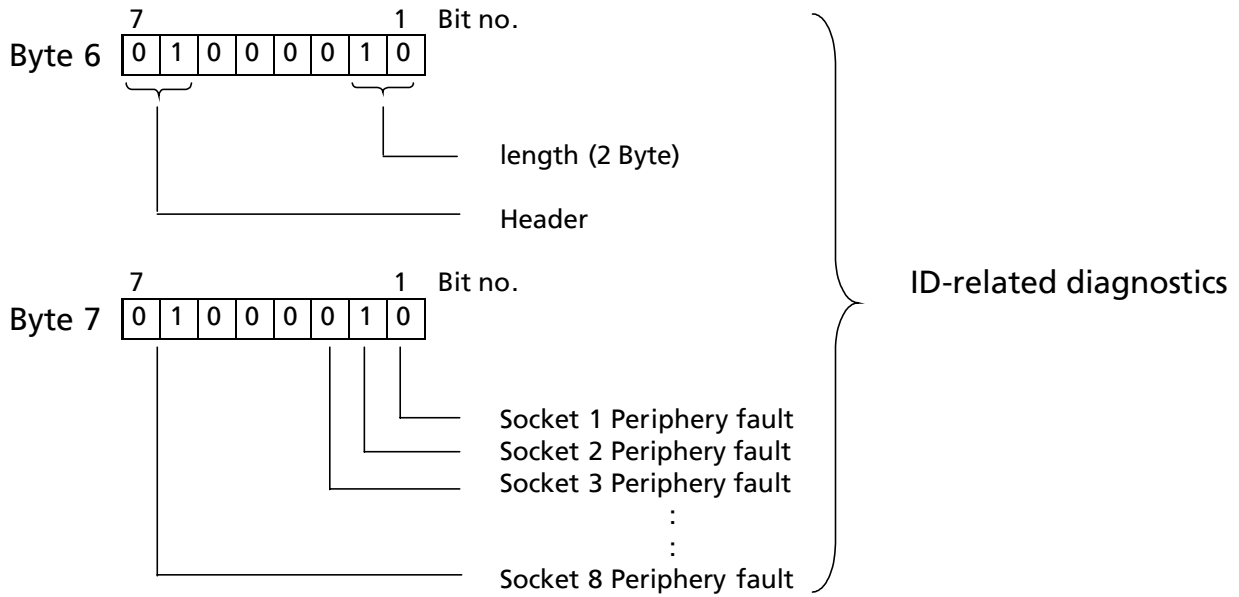

## Principles behind the structure of the channel diagnostics

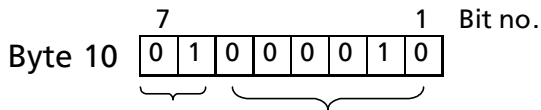

000001<sub>B</sub> to 001000<sub>B</sub> : ID number of the module which provides the channel -related diagnostics.  
The plug-in position of the module is coded. The following applies: displayed No. + 1 ⇒ plug-in position of the module (3 ⇒ plug-in position 4; 4 ⇒ plug-in position 5; etc.)

Code for cable -related diagnostics

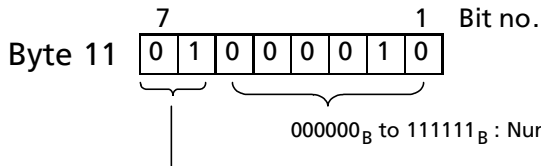

000000<sub>B</sub> to 111111<sub>B</sub> : Number of the channel that delivers the diagnostics.

Input/Output:   00<sub>B</sub> : DESINA or reserved  
                  01<sub>B</sub> : Input  
                  10<sub>B</sub> : Output  
                  11<sub>B</sub> : Input / Output

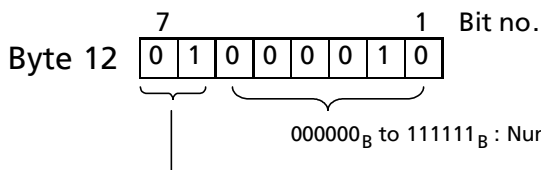

000000<sub>B</sub> to 111111<sub>B</sub> : Number of the channel that delivers the diagnostics.

Channel type:   001<sub>B</sub> : Bit  
                  010<sub>B</sub> : 2 Bit  
                  011<sub>B</sub> : 4 Bit  
                  100<sub>B</sub> : Byte  
                  101<sub>B</sub> : Word  
                  110<sub>B</sub> : Double word

Byte 13 to 15       Next channel-related diagnostics message (allocation as with bytes 10 to 12)

The undervoltage diagnostics of the actuator system power supply can be switched off with DIP switch No. 1, next to the addressing switches (see illustration below), as needed – e.g. when utilising the 0970 PSL 700 universal module solely as an input module. Should however one channel be triggered as an output, then the diagnostics will continue to be evaluated, visually as well as by means of the software!

## 5. Technical data

### 5.1 General data

Degree of protection	IP 67 (only in locked position)
Operating temperature range	-10°C / +60°C
Weight	380 g
Housing	PBT
Vibration resistance oscillations	15 g / 5–500 Hz
Vibration resistance shocks	50 g / 11 ms
Torques	
Fastening screw M4	1.0 Nm
Connector M12	0.6 Nm

### 5.2 Technical data – Bus system

Protocol	Profibus DP
ID no.	09CA hex
GSD file	Lum_09CA.gsd
Data transmission rates	9,6 / 19,2 / 45,45 / 93,75 / 187,5 / 500 KBit/s 1,5 / 3,0 / 6,0 / 12,0 MBit/s
Adjustment of the data transmission rate	automatic at the start of communications
Address range:	
Adjustment via Profibus:	1–126 dec (address switch: "00")
Adjustment via address switch:	1–99 dec
Default address	99 dec Please see chapter 4.1: Addressing
Connection	M12 male/female connector, 5 poles; please see pin assignment

### 5.3 Technical data power supply – Electronics/Sensors

Rated voltage $U_s$	24 V DC
Voltage range	19–30 V DC
Power consumption Electronics	typ. 70 mA
Voltage Sensors	min. ( $U_{system} - 1.5 V$ )
Power consumption Sensors	max. 200 mA (at $T_u$ 30°C)
Reverse polarity protection	yes
Indication ( $U_s$ )	LED green
Connection	7/8" male/female connector, (5 poles, please see pin assignment)

### 5.4 Technical data power supply – Actuators

Rated voltage $U_L$	24 V DC
Voltage range	19–30 V DC
Galvanic separation	yes
Undervoltage threshold	typ. 17 V
Delay time	
Undervoltage detection	< 20 ms
Reverse polarity protection	yes
Indication Actuator supply $U_L$	LED green
Connection	7/8" male/female connector, 5 poles; please see pin assignment

### 5.5 Technical data – Inputs

Input circuit	Type 3 according to IEC 61131-2
Rated input voltage	24 V DC
Input current at 24 V DC	typ. 5 mA
Short-circuit proof	yes
Channel type N.O.	p-switching
Number of digital channels	16
Status indication	LED yellow per channel
Diagnostic indication	LED green per socket
Connection	M12 female connector, 5 poles; please see pin assignment

### 5.6 Technical data – Outputs

Output circuit	Type 1.6 A according to IEC 61131-2
Rated output current per channel:	1.6 A, please see Info 1
Signal state "1"	max. 1.9 A
Signal state "0"	max. 1 mA (according to specification)
Signal level of the outputs	
Signal state "1"	min. ( $U_L - 1 V$ )
Signal state "0"	max. 2 V
Short-circuit proof	yes
Max. output current per module	9.0 A, please see Info 2
Overload-proof	yes
Number of digital channels	16
Channel type N.O.	p-switching
Status indication	LED yellow per channel
Diagnostic indication	LED red per channel/socket
Connection	M12 female connector, 5 poles; please see pin assignment

The reverse polarity protection only works if the actuator system power supply is protected by a current overload fuse (10 A, mT) and switches off no later than 10–100 ms after a short circuit has occurred.

#### ⚠ NOTE!

A power pack with current regulation or an incorrect fuse will result in the destruction of the module in the event of reverse polarity.

**Info 1:** The outputs are able to switch currents of 1.6 A with a frequency of 1 Hz with inductive loads of the utilization category DC13 (EN60947-5-1).

**Info 2:** Test proven and approved under the following conditions:  
looped through System/Sensor power supply max. 2.5 A  
Power supply cable STL 204 (5 x 1 mm<sup>2</sup>)  
Operating temperature range max. 40°C  
max. output current 12 A



**Lumberg Automation – Belden Deutschland GmbH**

Im Gewerbepark 2  
58579 Schalksmühle  
GERMANY  
Tel. +49 (0) 23 55 - 83-01  
Fax +49 (0) 23 55 - 83-3 33  
info@lumberg-automation.com  
www.lumberg-automation.com

**Lumberg Automation Support & Service**

Lumberg Automation offers you comprehensive technical assistance, helping you with the application of Lumberg Automation products.

support@lumberg-automation.com